

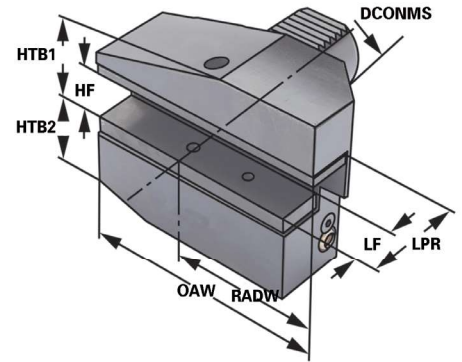

Verwendung:
Vorwiegend für Außenbearbeitung.
Zum Plan Einstechen.

Application:
Mainly for external machining.
For face machining.

Application:
Principalement pour usinage extérieur.
Pour carottage.



DIN ISO 10889

B7

Bestell-Nr. Order no. Référence	Abmessung Size Dimension	DCONMS	OAW	RADW	RADWOF	LF	LPR	HF	HTB1	HTB2
169.37.12	B7 - 16 × 12 × 24	16	58	39	5	13	24	12	20	22
209.37.16	B7 - 20 × 16 × 30	20	75	50	7	16	30	16	30	25
259.37.16	B7 - 25 × 16 × 30	25	75	50	7	16	30	16	30	25
309.37.20	B7 - 30 × 20 × 40	30	100	65	10	22	40	20	42	30
409.37.25	B7 - 40 × 25 × 44	40	118	75,5	12,5	22	44	25	48	42,5
509.37.32	B7 - 50 × 32 × 55	50	130	80	16	30	55	32	60	50

Ausführung: Mit einstellbarer Kugelspritzdüse und Unterlegplatte
Version: With adjustable spray nozzle and shim
Version: Avec gicleur ajustable et semelle

7



7.50



7.50

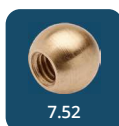

7.52

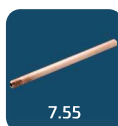

7.55